

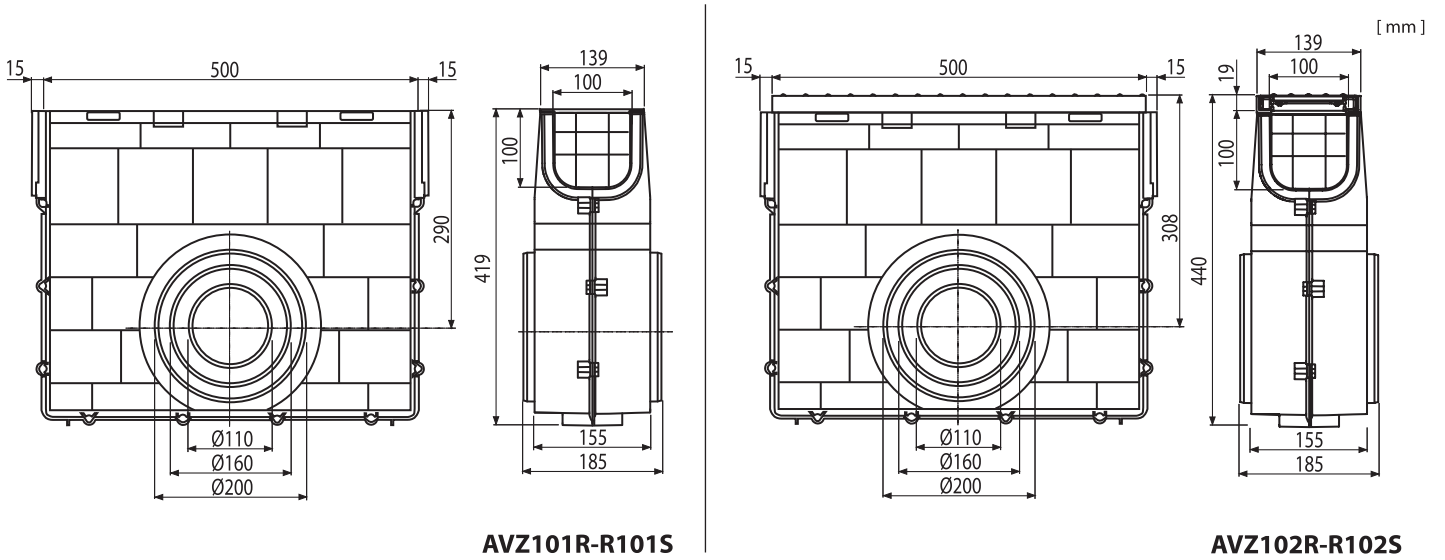

AVZ101R-R101S ■ AVZ102R-R102S - „A15“

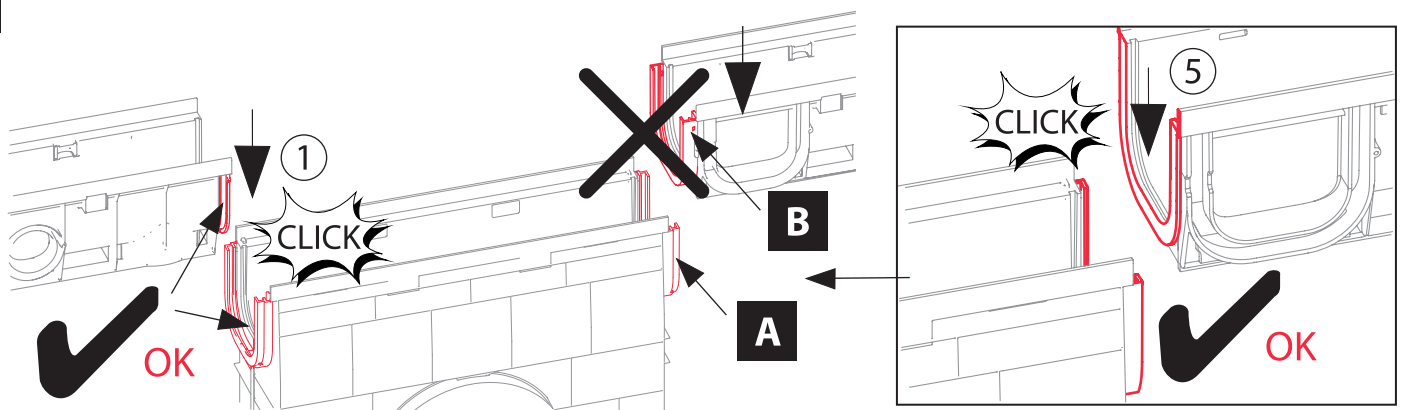

1



A

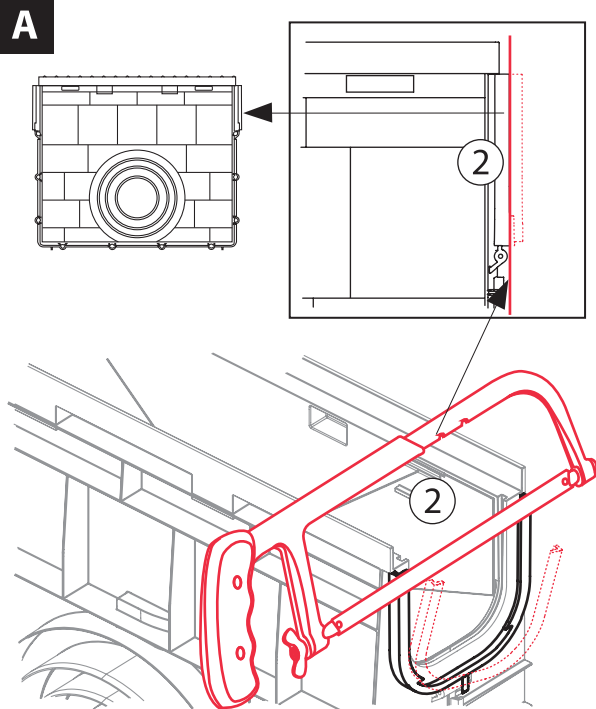

B

