

Jacob Delafon

E3872

**NOTICE TECHNIQUE
INSTRUCTIONS
INSTRUCCIONES**

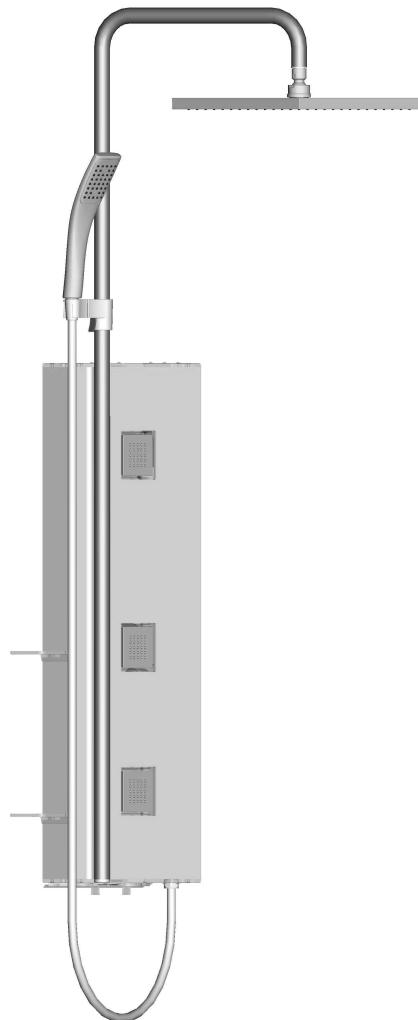

Une marque de la Société KOHLER FRANCE - 330 339 144 RCS BOBIGNY
Siège Social : Immeuble Le Cap - 3, rue de Brennus
93631 La Plaine St Denis cedex
TEL. : 33 (0) 1 49 17 37 37 - FAX : 33 (0) 1 49 17 37 40
www.jacobdelafon.fr
SERVICE ASSISTANCE CLIENTELE : ☎ 0810 307 000

Jacob Delafon España, S.A. - Kohler Group
Carretera de Logroño, Km.17
50629 Sobradiel (Zaragoza)
SERVICIO ATENCIÓN AL CLIENTE: ☎ 902 46 46 86
www.jacobdelafon.es
SERVICIO ASISTENCIA TÉCNICA: ☎ 902 11 38 36

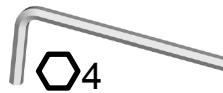
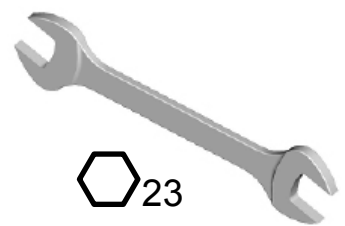
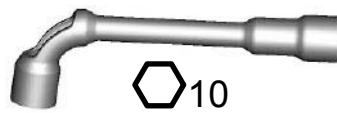
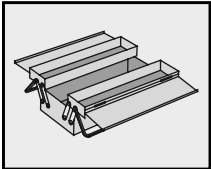
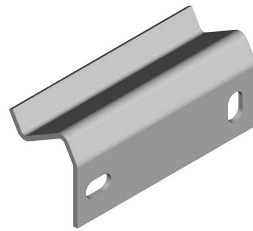
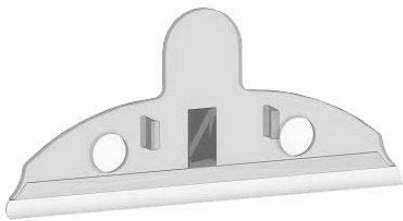
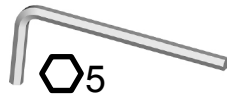
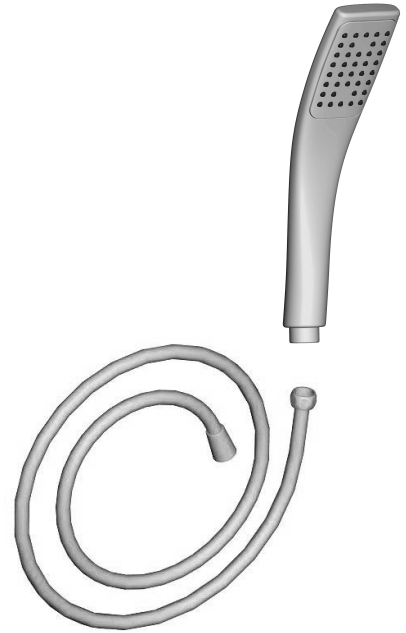
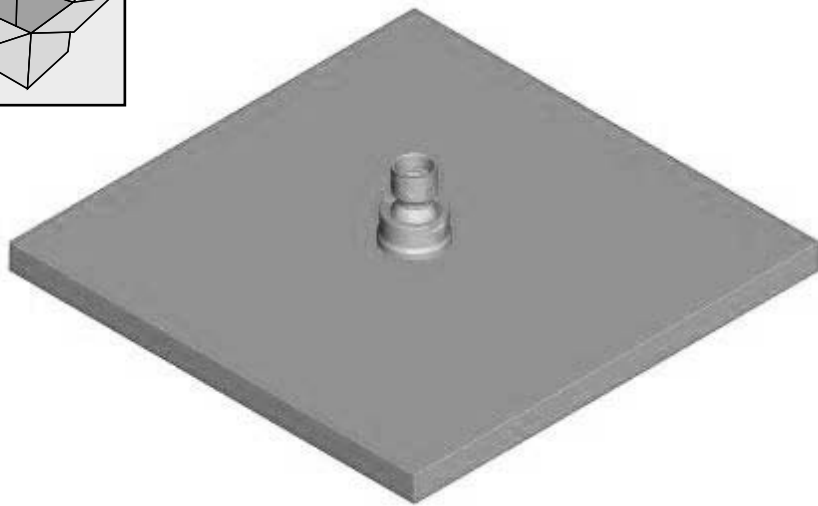
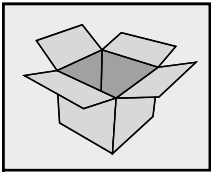

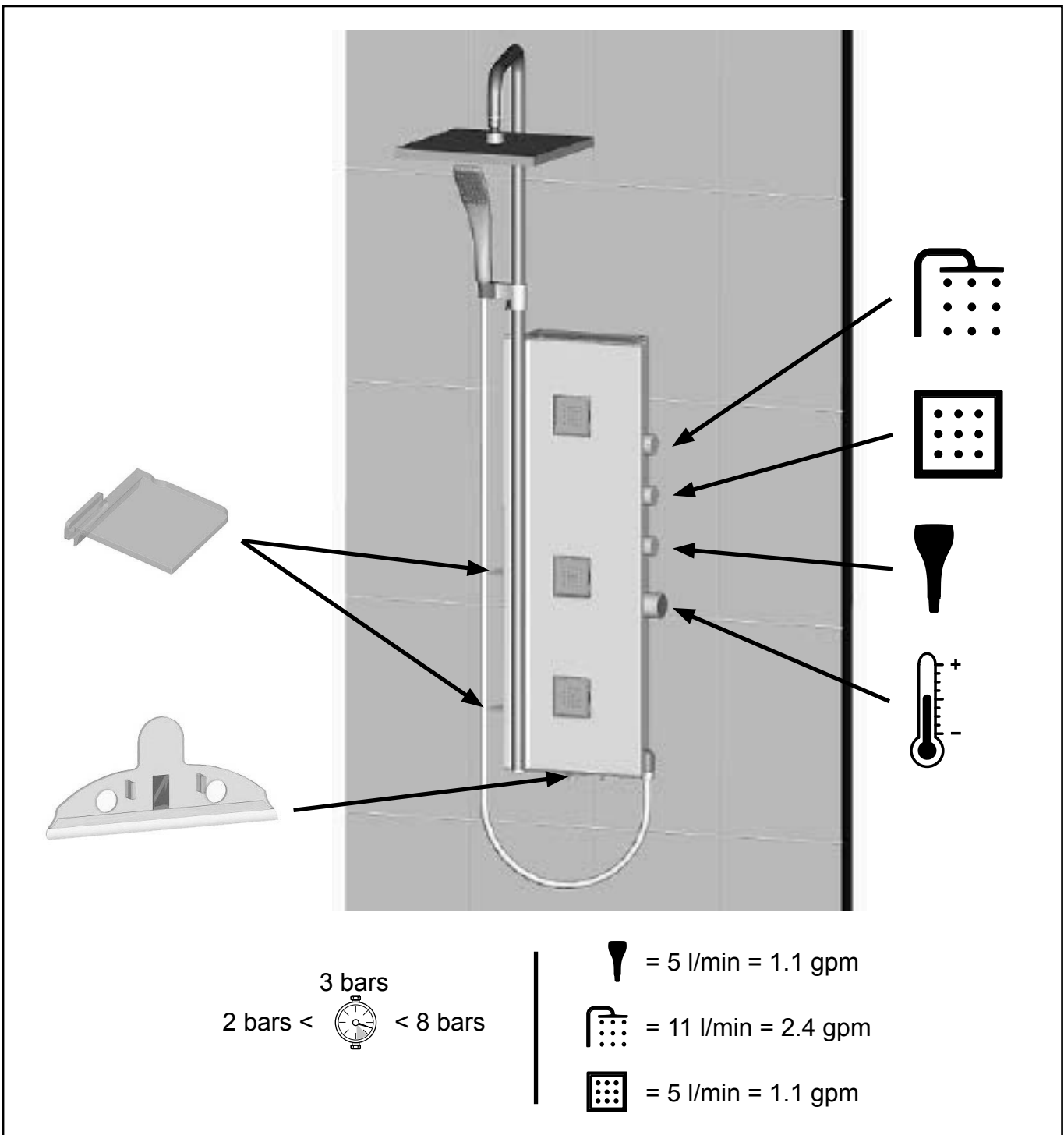

Chauffe-eau instantané: Le panel peut se raccorder à un chauffe-eau instantané avec une puissance minimum de 24 kw.

Pression: La pression d'entrée au panel doit être au minimum de 1.5 bar dynamique.

Si la différence de pression entre les branchements eau chaude et eau froide est trop importante, nous vous conseillons d'installer un équilibreur de pression.

Instantaneous gas water heater: The panel can be connected to an instantaneous gas water heater with a minimum power of 24 kw.

Pressure: The inlet pressure of the panel must be at least of 2 dynamics bars. If the difference in pressure between the hot water and the cold water is too important, we advise you to install a flow equalizer.

Calentador instantáneo: El panel puede unirse a un calentador instantáneo con una potencia mínima de 24 kw.

Presión: La presión de entrada al panel debe ser de al menos de 1,5 bares en dinámica.

Si la diferencia de presión entre la fría y la caliente es excesiva, le aconsejamos instalar un regulador de presión.

1

①

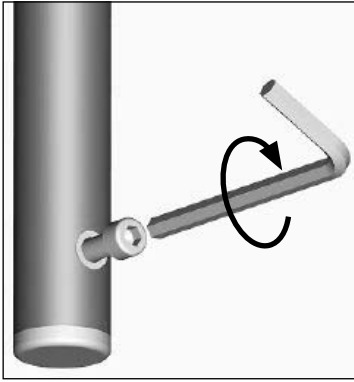

②

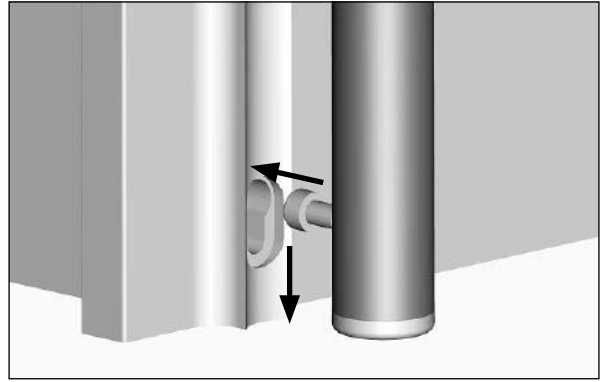

③

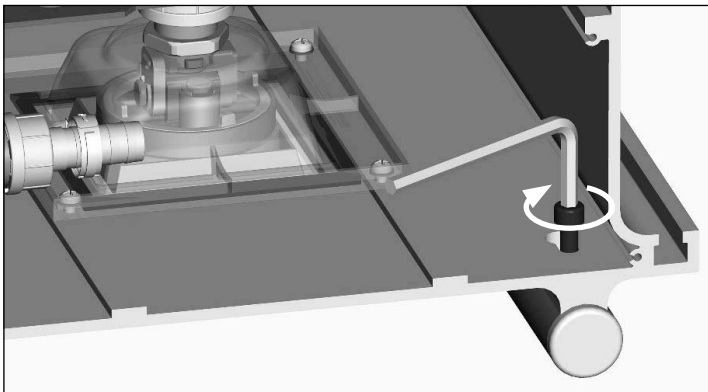
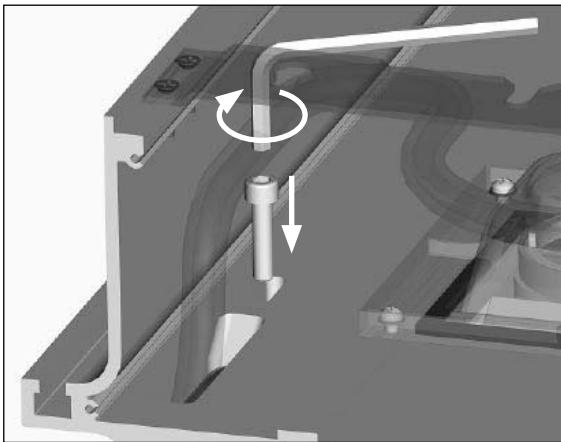
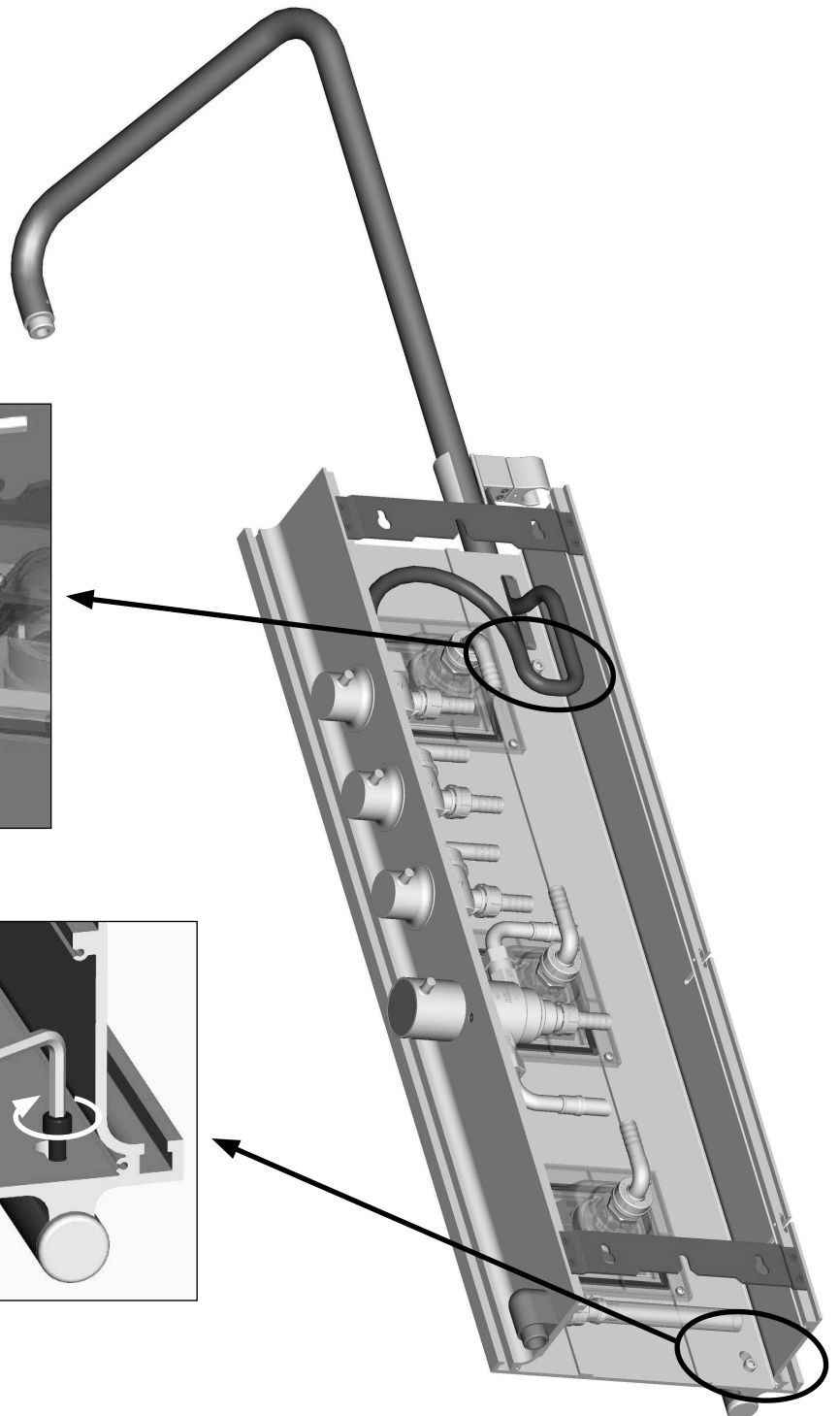

2

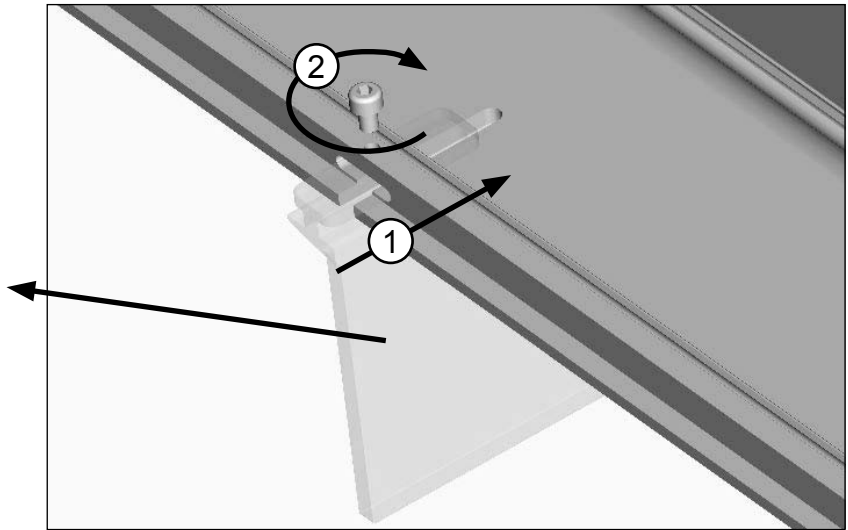
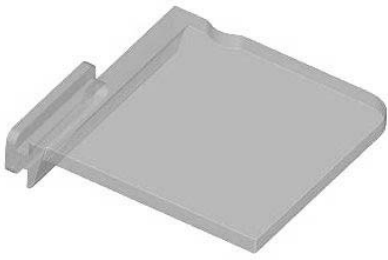

3

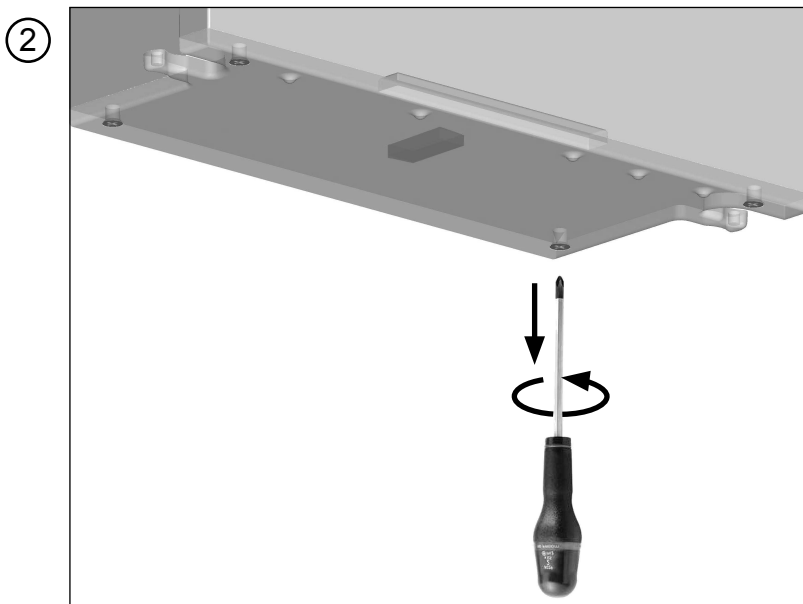
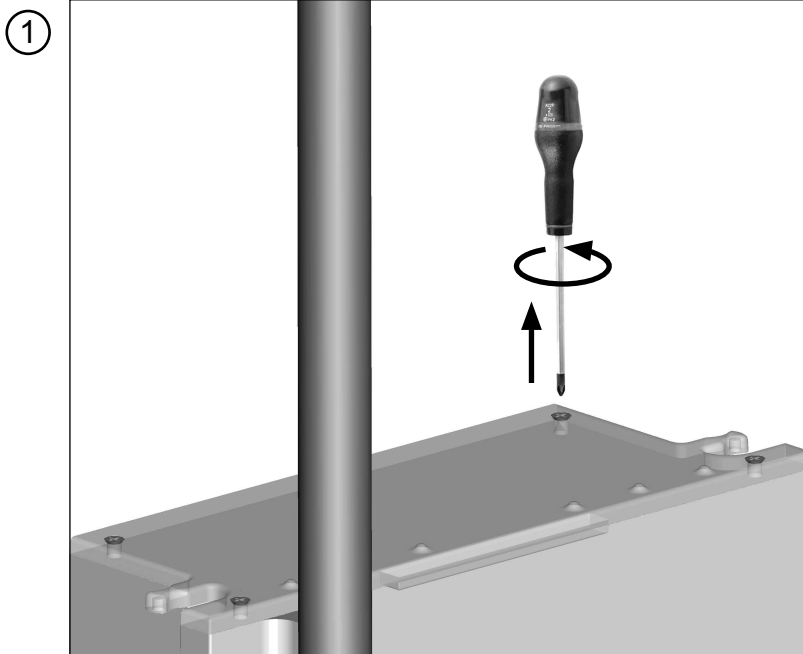

4

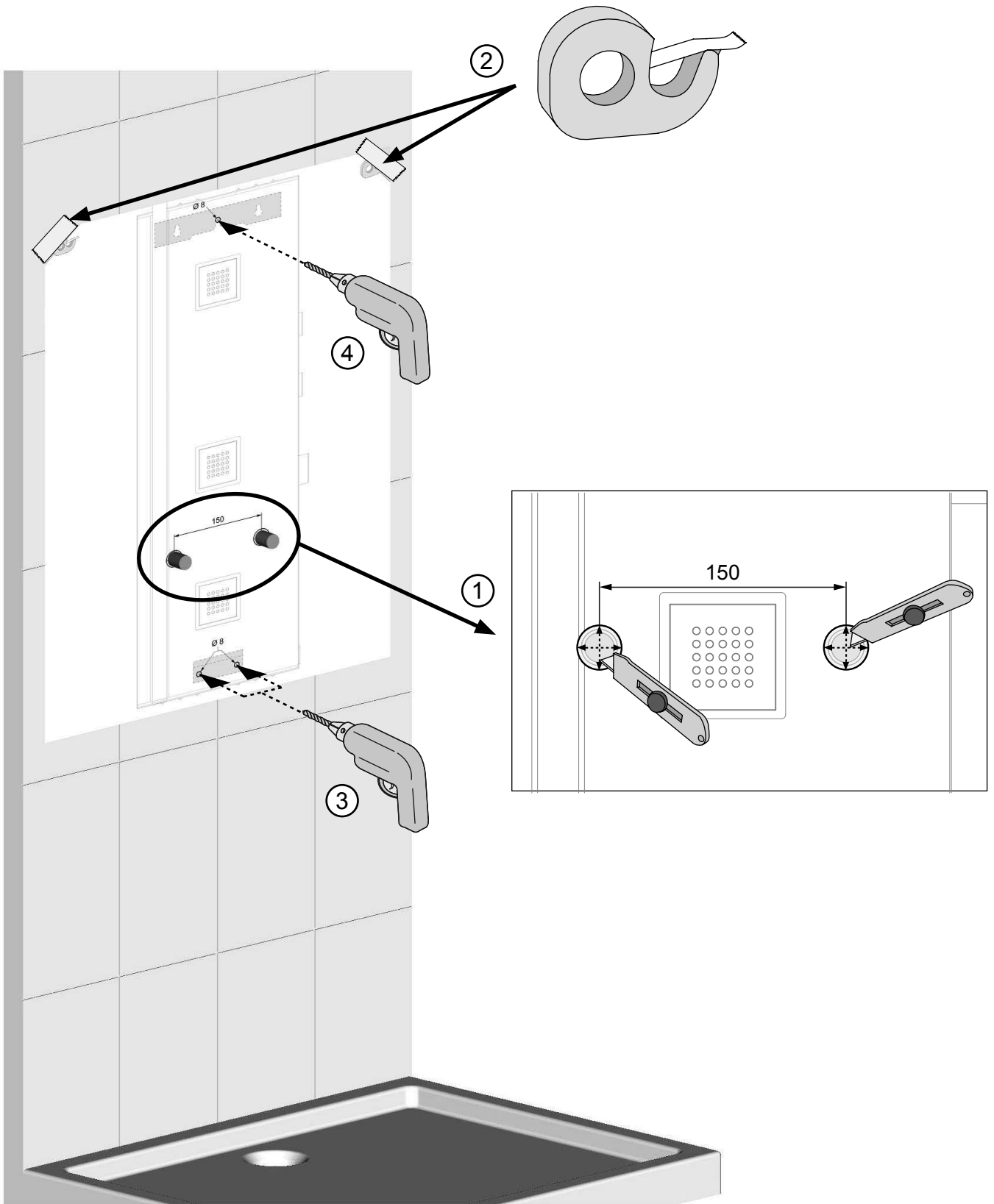

5

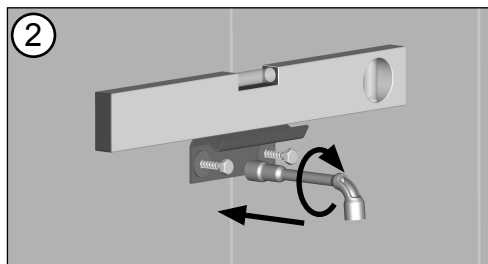
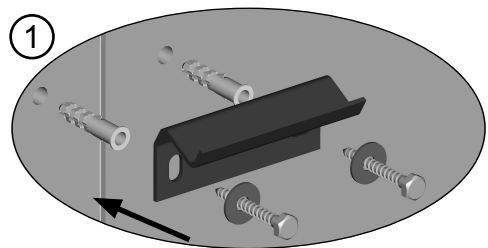
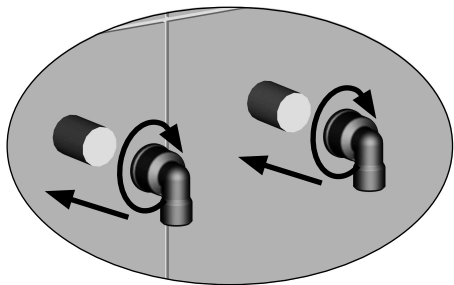
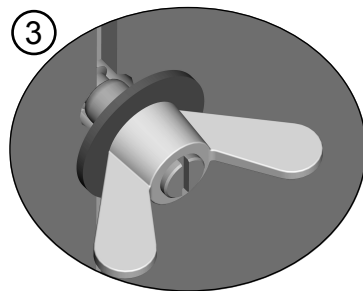
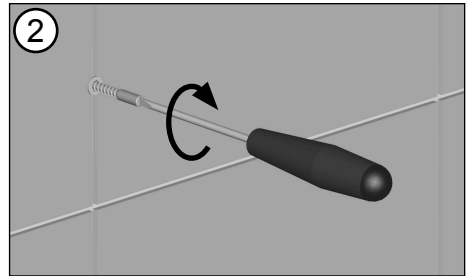
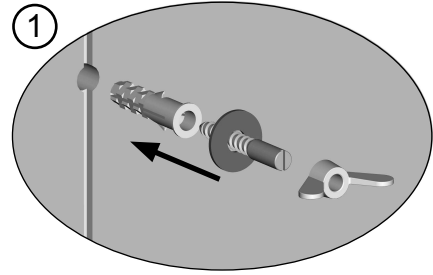
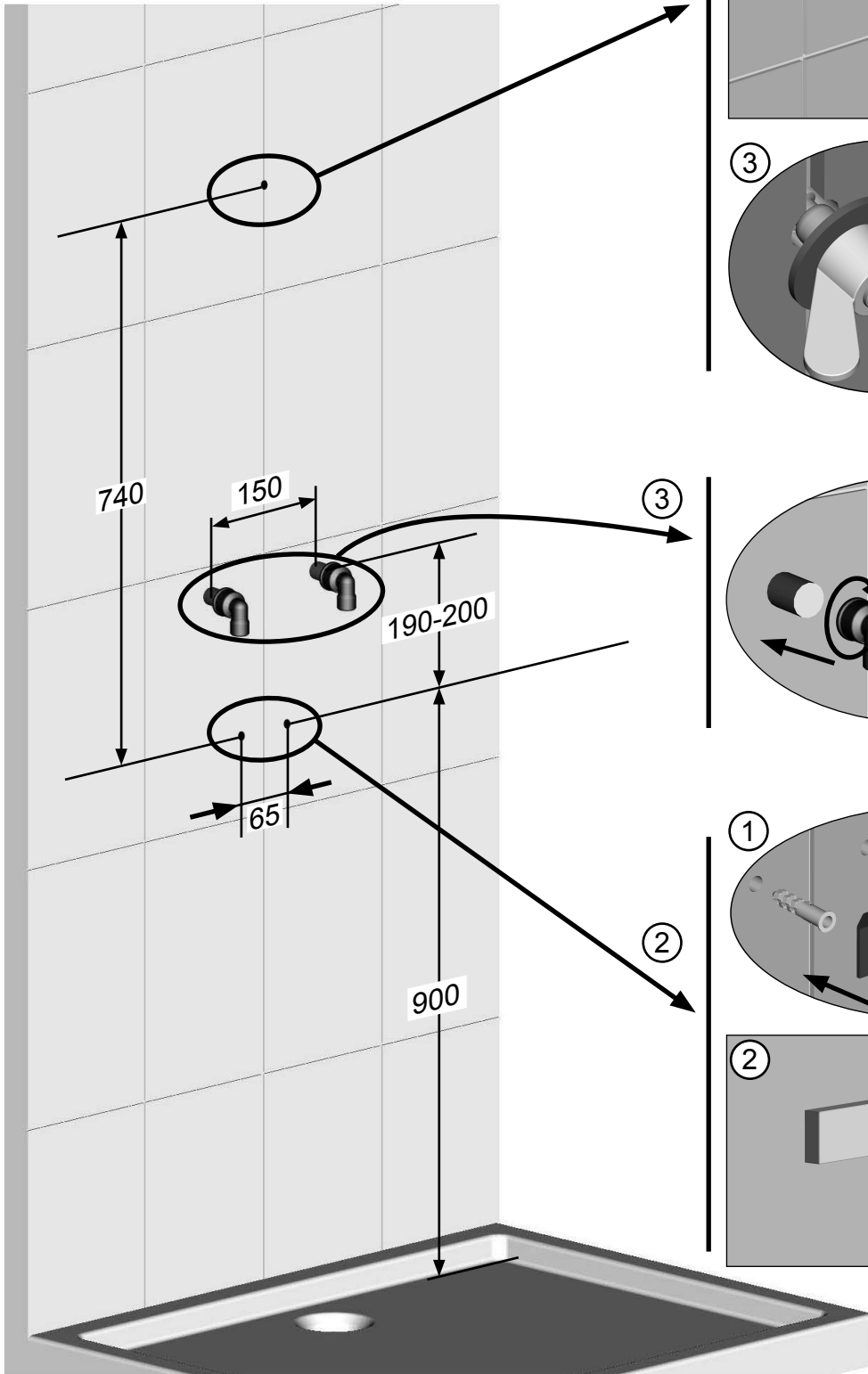

6

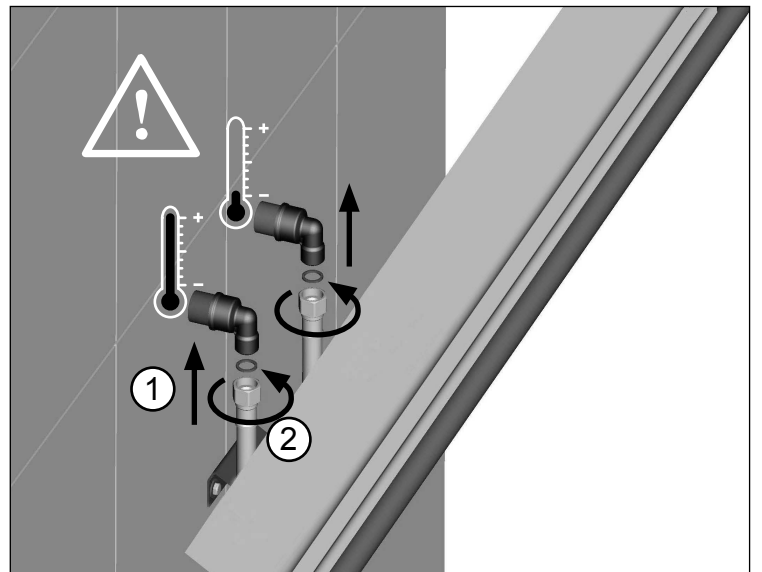
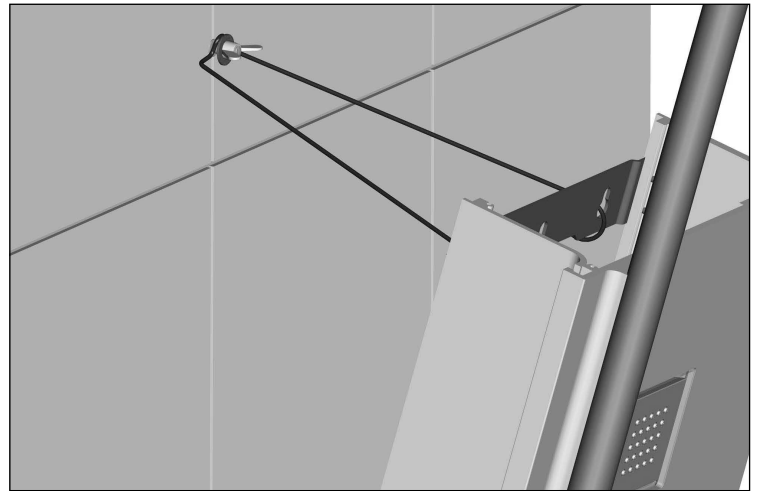
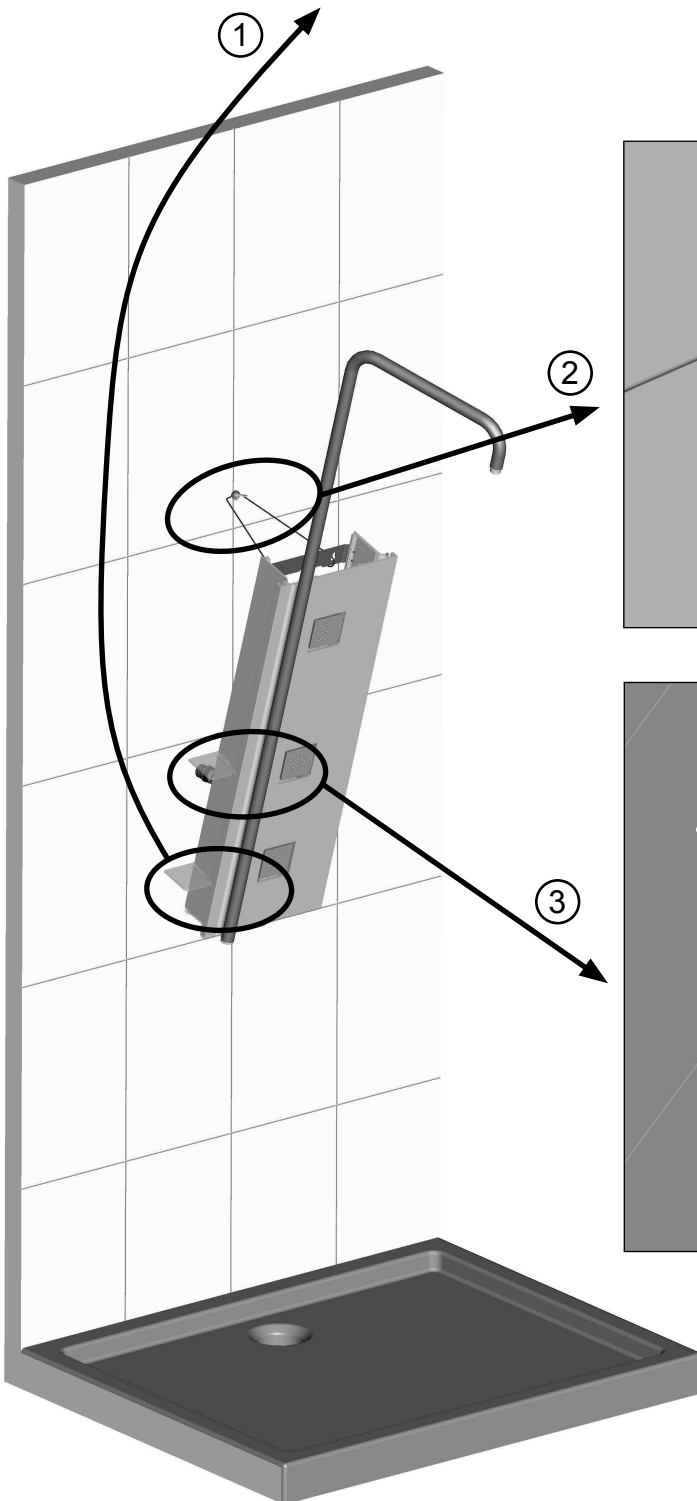
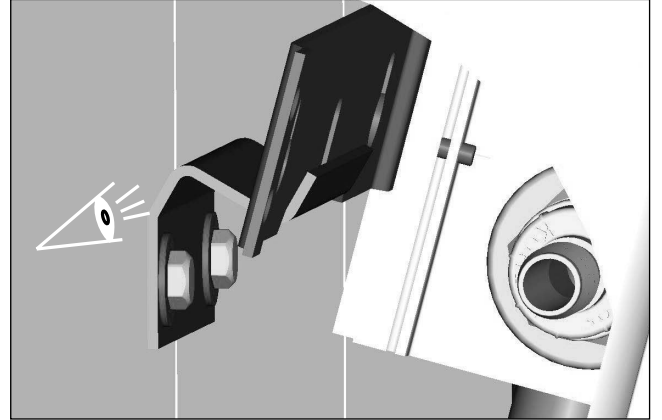
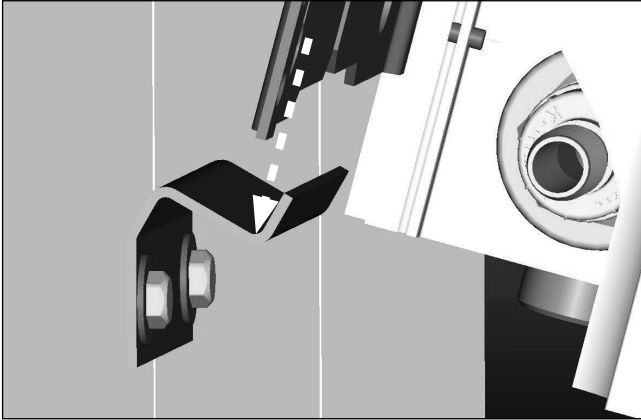

7

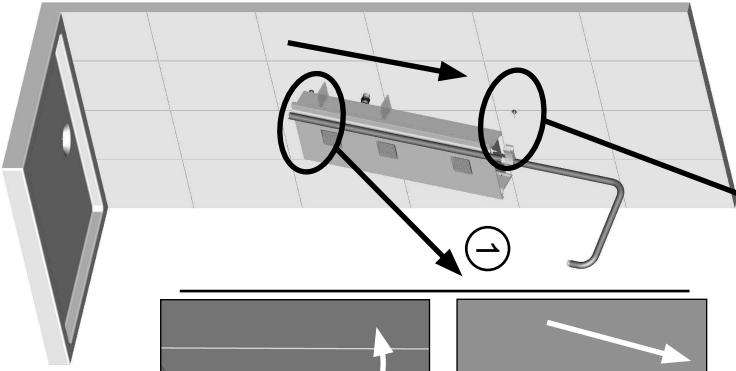

A

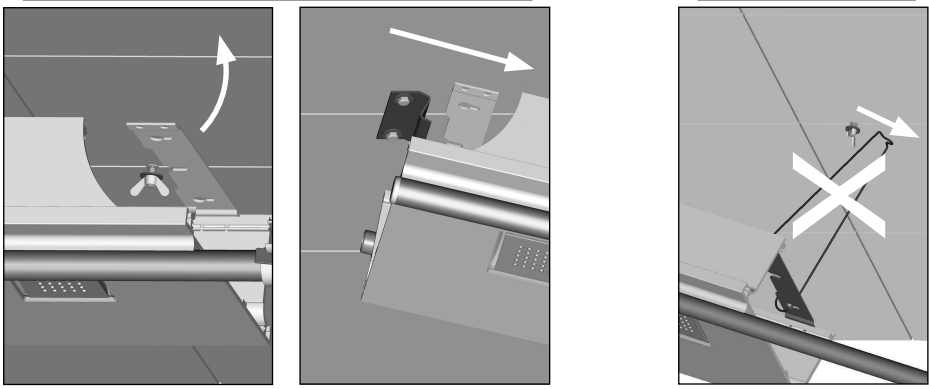

B

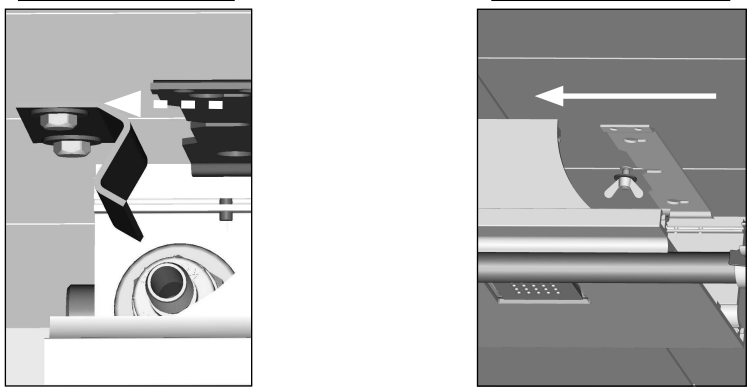
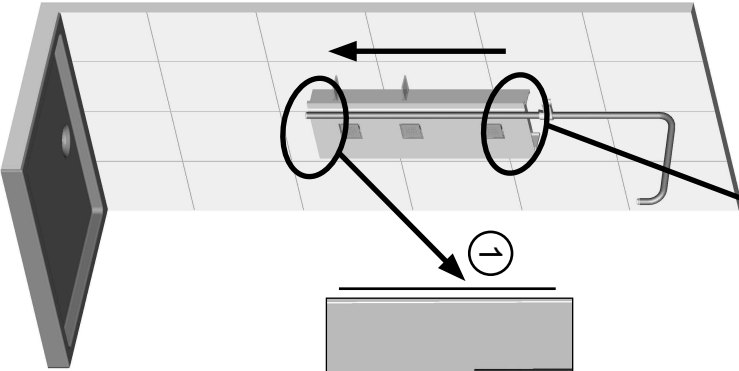

C

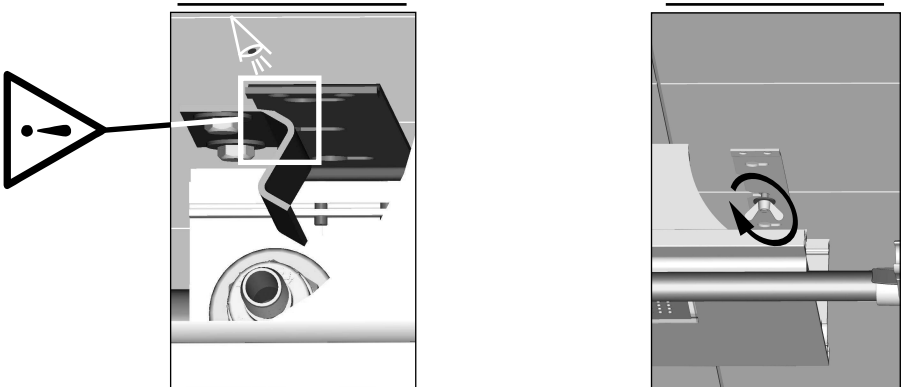
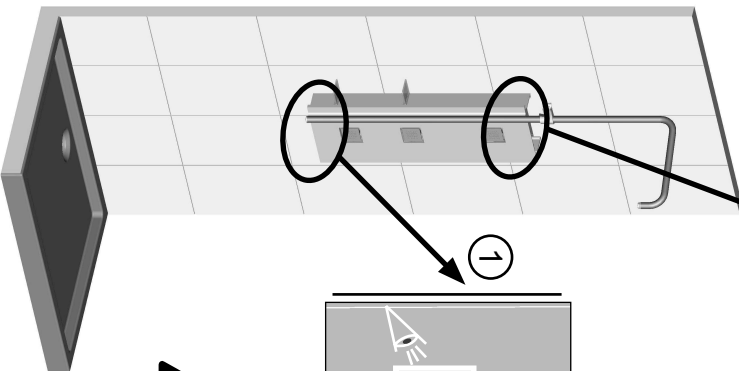

8

1

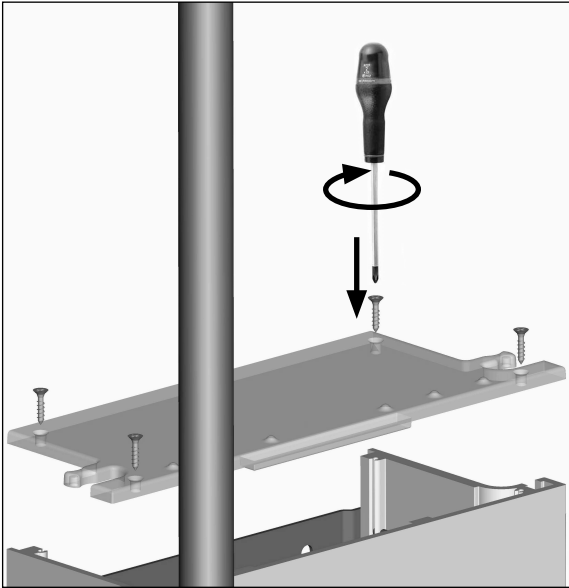

2

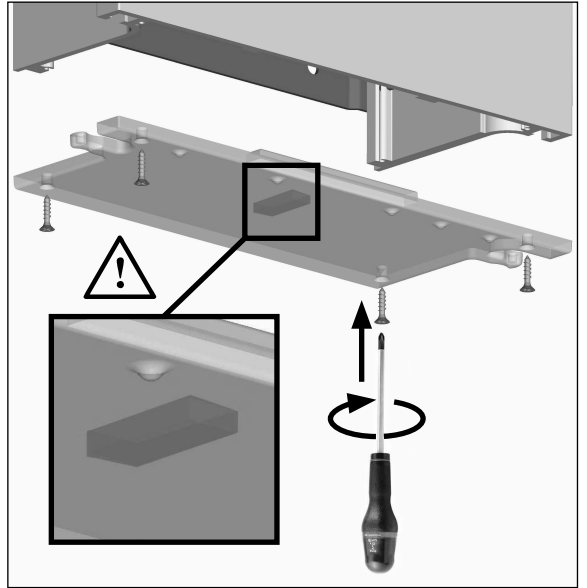

9

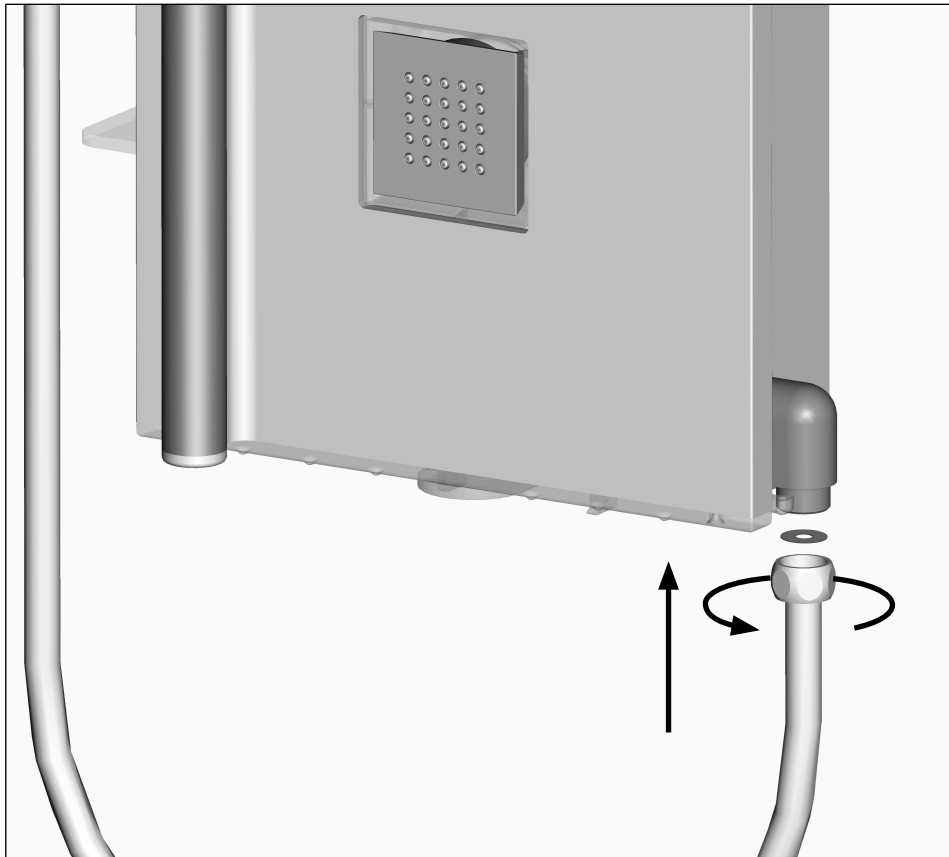

10

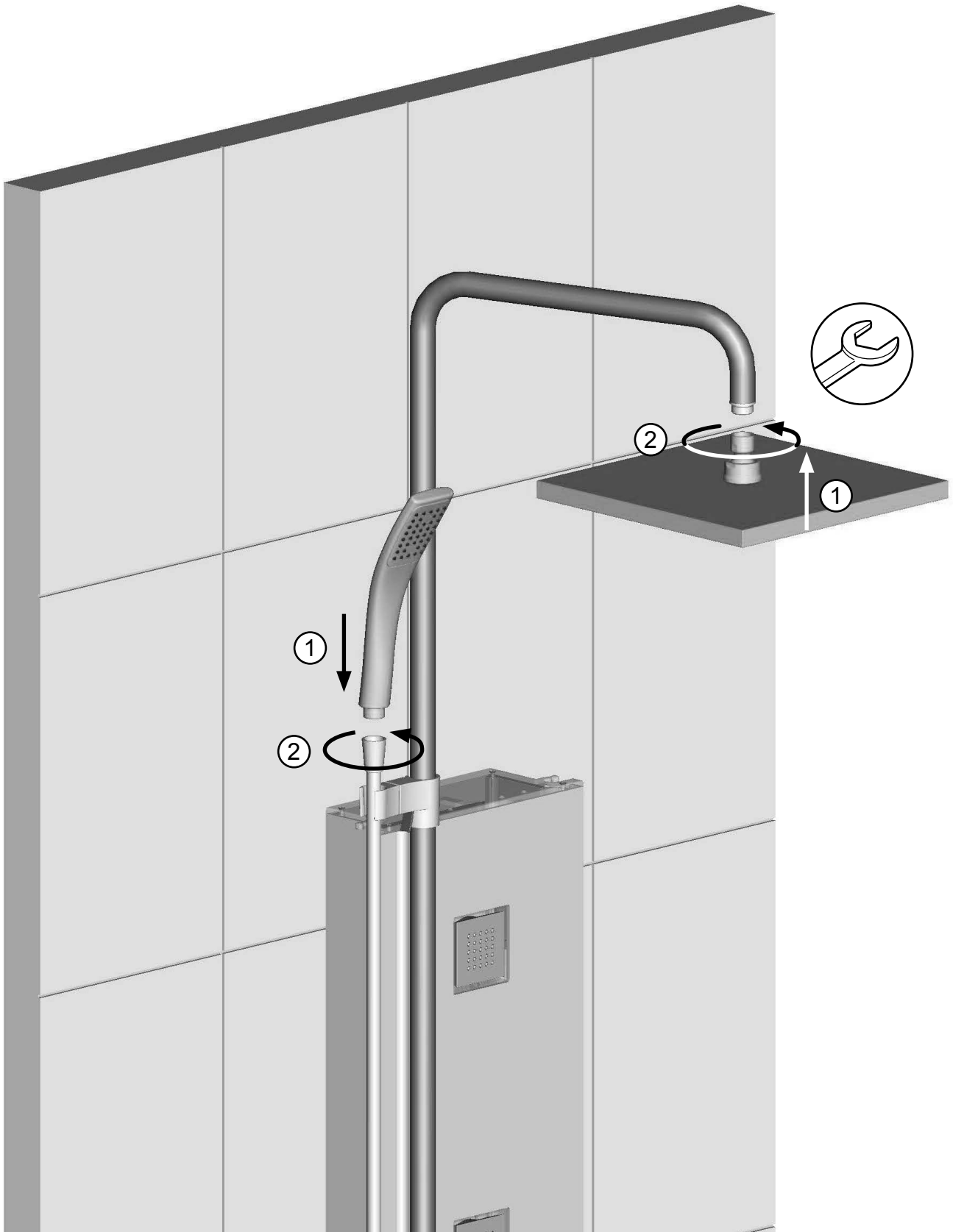

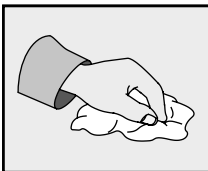

①

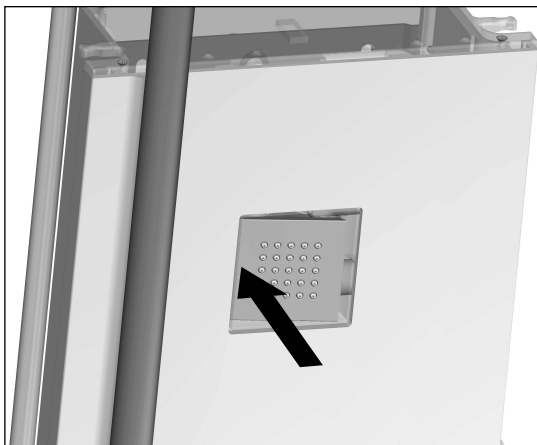

②

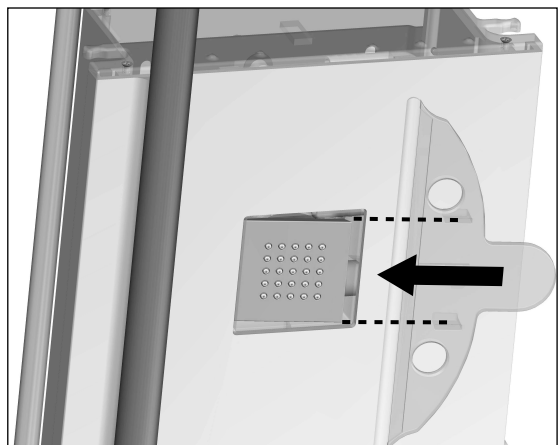

③

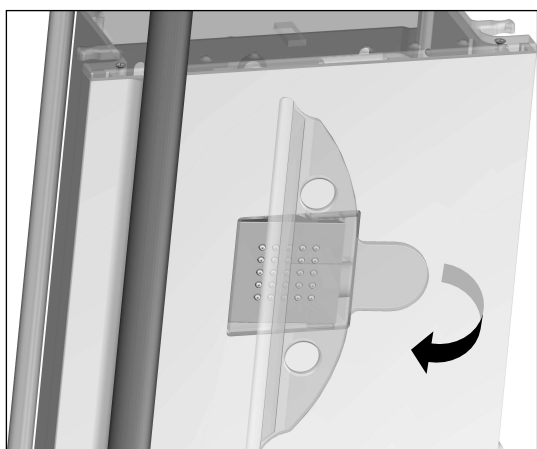

④

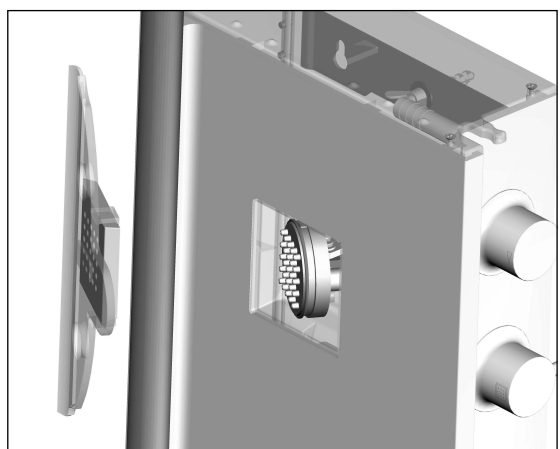

⑤

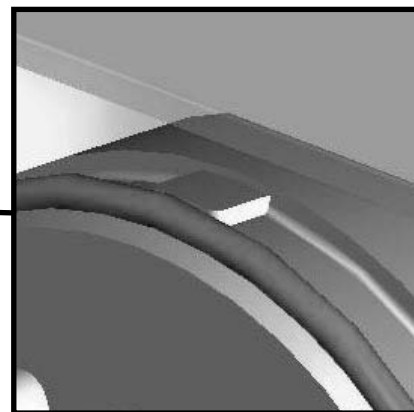
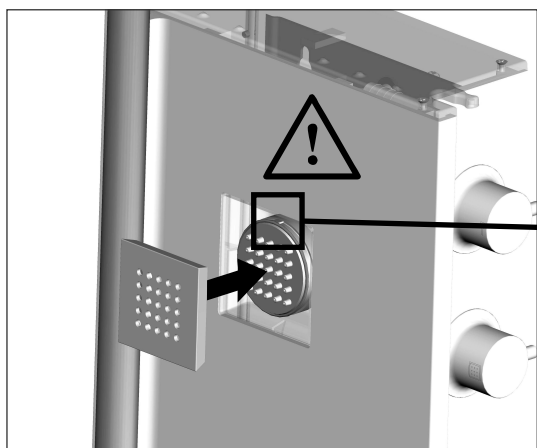



• La finition de cet équipement de douche exige une attention particulière. Pour conserver son aspect, nettoyer régulièrement sa surface avec une éponge savonneuse non abrasive, bien rincer et essuyer avec un linge doux. Nous vous conseillons après chaque douche d'utiliser la raclette fournie. Evitez formellement l'utilisation des produits contenant de l'alcool méthylique, des acides, des solvants ou des abrasifs qui endommageraient le revêtement.

• This shower product has a finish which requires special care. To maintain its shine and luster, clean regularly with a non-abrasive sponge and soap, rinse thoroughly and dry with a soft cloth. Do not use harsh products containing methyl alcohol, acids, solvents or abrasives that can damage the finish.

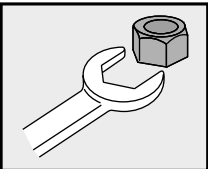
• El acabado de este equipo de ducha exige un mantenimiento bastante simple. Para conservar su aspecto, limpiar con una esponja jabonosa no abrasiva, aclarar bien y secar con un paño suave. Le aconsejamos utilizar tras cada ducha la rasqueta suministrada. Evitar absolutamente la utilización de productos que contengan alcohol metílico, ácidos, disolventes y abrasivos que pudieran dañar el acabado.



E8A713-CP 
 E8A714-CP 
 E8A715-CP 

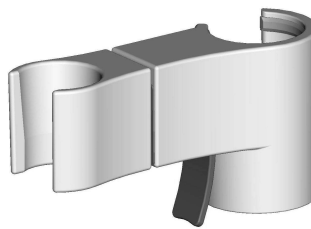

E8A703-CP

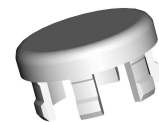

R8A707NF



R8A763NF

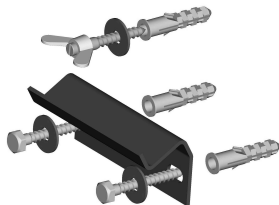

R8A723NF

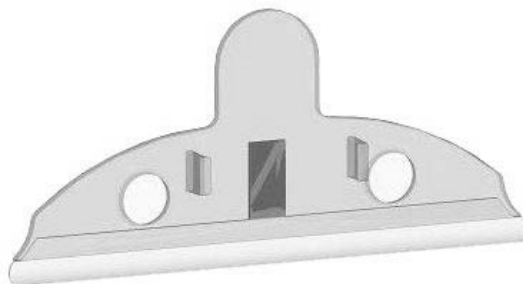

R8A708NF

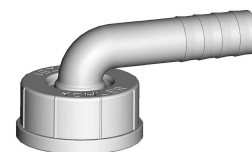

G 1/2" = R8A709NF
 G 1" = R8A710NF

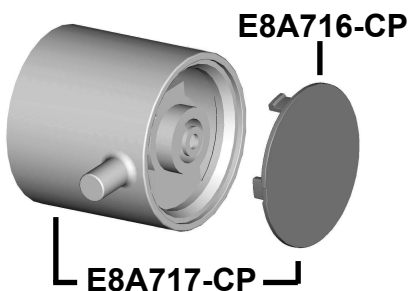

E8A716-CP

E8A717-CP

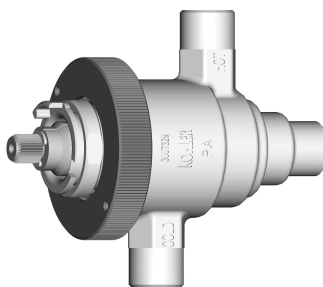

R8A706NF

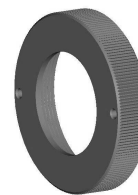

R8A761NF



R29305239

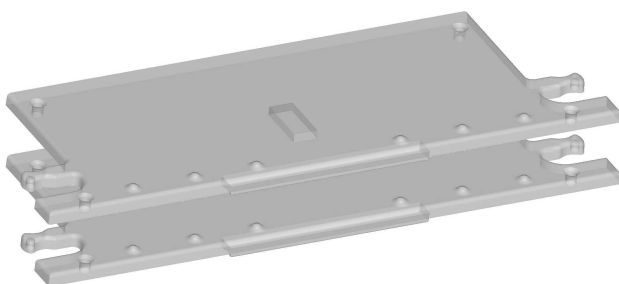

R8A702NF

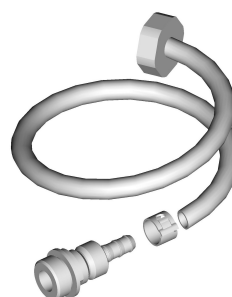

E8A722-CP



E8A718-CP

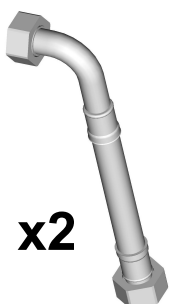

x2

R8A720NF



R8A705NF

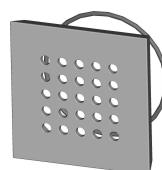

R8A778NF

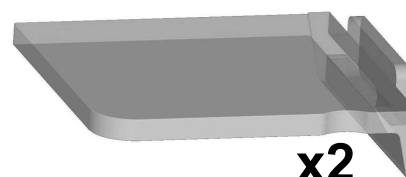

x2

R8A704NF

Jacob Delafon

Une marque de la Société KOHLER France – 330 339 144 RCS Bobigny	Jacob Delafon España, S.A. - Kohler Group
SIÈGE SOCIAL Immeuble le Cap 3, rue de Brennus	Carretera de Logroño, Km.17
96631 La Plaine St Denis cedex	50629 Sobradiel (Zaragoza)
Tel : 00 33 (0)1 49 17 37 37 - 0 810 05 89 33	SERVICIO ATENCIÓN AL CLIENTE: 902 46 46 86
www.jacobdelafon.fr	www.jacobdelafon.es
Service assistance technique 0810 30 7000	SERVICIO ASISTENCIA TÉCNICA: 902 11 38 36

3008627-2-G